



# MAGLOGIX<sup>®</sup>

## Operation Manual

### MagnaHoist<sup>®</sup> MXL-1000.R

**EN** Lifting Magnet



## Contents

Safety Instructions	3
Proper Use, Device Description	4
Technical Data, Markings on the Lifting Magnet	5
Start-up	6
Pivoting or Vertical Lifting of Loads, Adjustable Shock Absorber	8
Basic Information on the Load-bearing Capacity of the MXL-1000.R	10
Maintenance and Inspection	11
Detailed Performance Data for Use on Flat Material	12
Detailed Performance Data for Use on Round Pipes	13
EC Declaration of Conformity	14

**Before use read and save these instructions!**

Dear customer,

Thank you for purchasing a Maglogix<sup>®</sup> product. Read these operation instructions closely before using your device for the first time and keep them along with the enclosed *Product Control Card* for later reference.

## Safety Instructions

Serious accidents with fatal physical injuries can occur when using extremely strong lifting magnets if they are improperly used and/or maintained. Observe all safety instructions in this operation manual and contact the manufacturer if you have any questions.



### Always...



- activate the lifting magnet completely
- activate the lifting magnet on metallic, ferromagnetic materials
- use the entire magnetic surface for lifting
- lift on plane surfaces
- lift round pipes with the admissible diameter
- ensure that the pipe is positioned correctly in the groove of the lifting magnet
- check the magnetic holding force by lifting the load slightly by about 10 cm
- clean the magnetic surface and keep it clear of dirt, chips and welding sputter
- set the lifting magnet down gently to prevent damage to the magnetic surface
- check the hazard area before pivoting the load
- respect the stated maximum load before pivoting
- inspect the magnetic surface and the entire lifting magnet for damage
- use suitable lifting gear
- follow the instructions in these operating instructions
- instruct new operators to the safe use of lifting magnets
- respect local, country-specific guidelines
- use and store in a dry place

### Never...



- exceed the stated maximum load
- lift arched objects or objects with free form surfaces
- lift round pipes of a too big or too small diameter
- lift loads over people
- perform lateral lifts of round pipes
- lift more than one work piece at a time
- switch the lifting magnet off before setting down the load safely
- allow the load to sway or bring to a sharp and immediate stop
- lift loads exceeding the recommended dimensions
- lift loads with cavities, cut-out openings or drilled holes
- lift unbalanced loads
- modify the lifting magnet or remove operating labels
- use the lifting magnet if damaged or missing parts
- strain the underside of the magnet through heavy impact or blows
- position yourself beneath the lifted load
- lift loads while people are within the hazard area
- leave the load hanging unattended
- use the lifting magnet without having been properly instructed
- use if you have not read and understood these operating instructions completely
- use the lifting magnet to support, lift or transport persons
- operate the lifting magnet in temperatures higher than 60°C (140°F)
- expose to corrosive substances



**People using pacemakers or other medical devices should not use this lifting magnet until they have consulted with their physician.**

## Proper Use

The MagnaHoist® permanent lifting magnet MXL-1000.R is designed to lift ferromagnetic, metallic loads and may only be used according to its technical data and determination. Proper use includes adherence to the start-up, operating, environment and maintenance conditions specified by the manufacturer. The user bears sole responsibility for understanding the operating manual as well as for proper use and maintenance of the lifting magnet.

## Device Description

The MagnaHoist® MXL-1000.R is a switchable lifting magnet with manual actuation for the lifting, transporting and lowering of ferromagnetic materials. By pressing the lever (F) down, the magnetic field generated by the permanent magnet can be activated in the lower magnetic plate (C) area.

Thanks to the special design, a very compact magnetic field is generated which develops excellent adhesive force, especially on thin materials (less than 10 mm). The magnet can be deactivated by first pressing the safety tab (E) with the heel of the hand and then moving the lever upwards. An adjustable oil damper is incorporated underneath the safety tab in order to absorb the recoil energy of the lever, especially during use on thin materials. Additional threads for mounting are located on either front side of the magnet which, if desired, can be used as holding device. An eyelet is situated on the top of the lifting magnet for attachment to a crane. The load-bearing capacity of the lifting magnet is equivalent to 1/3 of the maximum breakaway force of the magnet and thus is equivalent to the standard safety factor 3:1. A groove in the magnetic contact area (I) allows also for the lifting of round pipes.

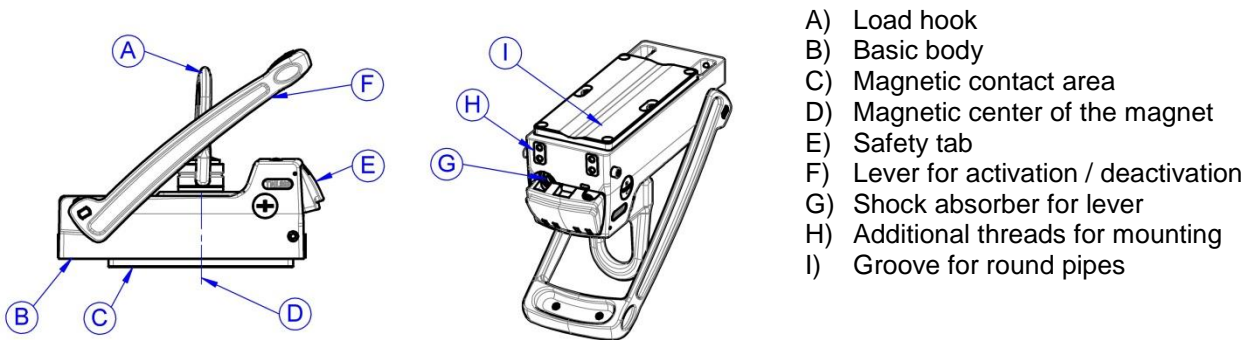

- A) Load hook
- B) Basic body
- C) Magnetic contact area
- D) Magnetic center of the magnet
- E) Safety tab
- F) Lever for activation / deactivation
- G) Shock absorber for lever
- H) Additional threads for mounting
- I) Groove for round pipes

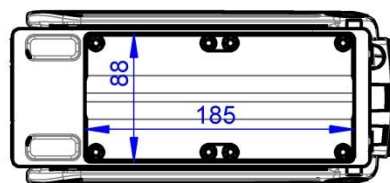
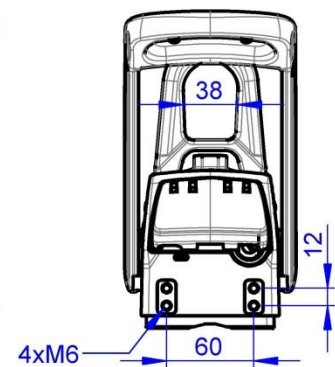
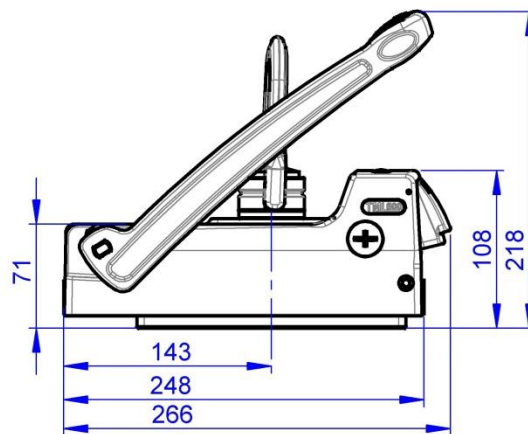
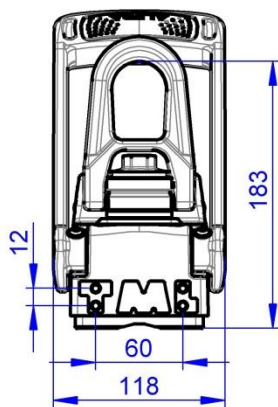

## Technical Data

Prod.-No.: **41500.R**

Designation: MagnaHoist® MXL-1000.R  
Lifting Magnet

Breakaway force: >1362 kg from 15 mm S235 >3000 lbs from ½" AISI CRS 1020

Max. load-bearing capacity:  
(on flat material  
with safety factor 3:1) 454 kg from 15 mm S235 1000 lbs from ½" AISI CRS 1020

Max. load-bearing capacity:  
(at 6° inclination acc. to EN 13155  
with safety factor 3:1) 400 kg from 15 mm S235 862 lbs from ½" AISI CRS 1020

Max. load-bearing capacity:  
(at 90° inclination of the load  
with safety factor 3:1) 136 kg from 15 mm S235 300 lbs from ½" AISI CRS 1020

Dead weight of the unit: 8.1 kg 17.8 lbs

Admissible diameter of round  
pipes: 50 - 400 mm 2" - 16"

Max. load-bearing capacity:  
(on round pipes at 0° inclination) 20 - 50% of the load-bearing  
capacity for flat material 20 - 50% of the load-bearing  
capacity for flat material

Storage temperature: -30°C to +60°C -22°F to +140°F

Operating temperature: -10°C to +60°C +14°F to +140°F

## Markings on the Lifting Magnet

Additional detailed descriptions for handling and operating conditions can be found on both sides of the lifting magnet. This labeling must not be modified, damaged or removed, as otherwise the manufacturer cannot be held responsible for any personal injuries, property damage or accidents resulting from this fact. New labels must be ordered from the manufacturer if necessary.

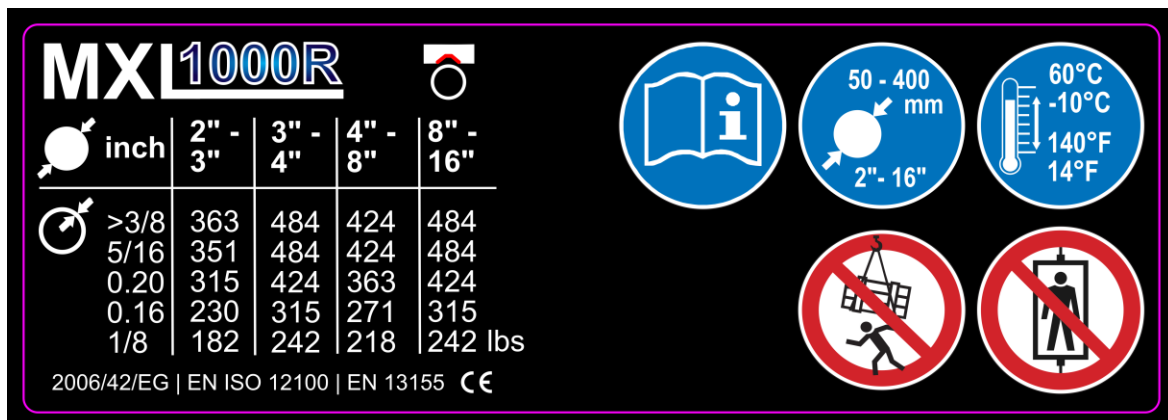
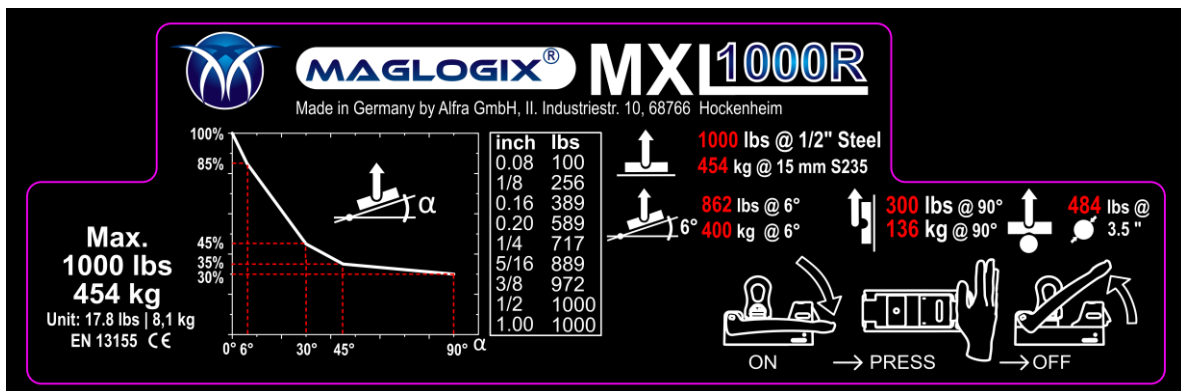

## Start-up

You have received a completely assembled MagnaHoist® MXL-1000.R lifting magnet and detailed operating manual. Please check the condition of the goods upon receipt for any damage incurred during transport, and make sure the delivery is complete. If you have any problems, please contact the authorized reseller or manufacturer immediately.



**Be sure to read the operation instructions completely before using this magnet for the first time!**

1. Follow the safety instructions. Clean the work piece and the lower magnetic plate of the lifting magnet.

**Note:** Although the activation lever of the MXL-Magnet is facing upwards (OFF position), the magnet still has a slight magnetic pre-tensioning. This pre-tension does not only allow for ease of positioning the lifting magnet to the workpiece, it also avoids inadvertent slippage or dropping of the lifting magnet or the workpiece (e.g. when used in a vertical or other forced position).

2. Position the lifting magnet at the center of gravity of the load.
3. Ensure that the workpiece is positioned correctly inside the groove of the magnetic contact area when using the MXL-1000.R on round material. Otherwise the magnet's load-bearing capacity is not ensured.
4. Align the lifting magnet ideally according to the desired application.
5. Press the activation lever down until it is fully engaged in the ON position. Make sure that it is securely locked underneath the safety tab.
6. Perform a test lift: Move the load hook to the required position and lift the load by about 10 mm to check its deformation and the magnetic holding force of the MXL-Magnet.
7. Check for any air gap developing at the edges of the magnetic surface contact area, for instance by means of a sheet of paper (80g/m<sup>2</sup>). If a small distance (air gap) forms between magnet and workpiece, the load-bearing capacity of the lifting magnet will be reduced significantly.

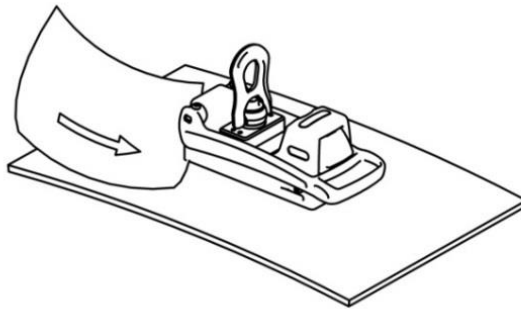

**Immediately stop the lift if there is any excessive deformation of the work piece or an air gap.**



**Use spreader bars with additional magnets to safely lift large or flexible loads.**



Never lift round pipes laterally. The workpiece could slip abruptly off the groove and disengage itself from the lifting magnet. Danger of injury!

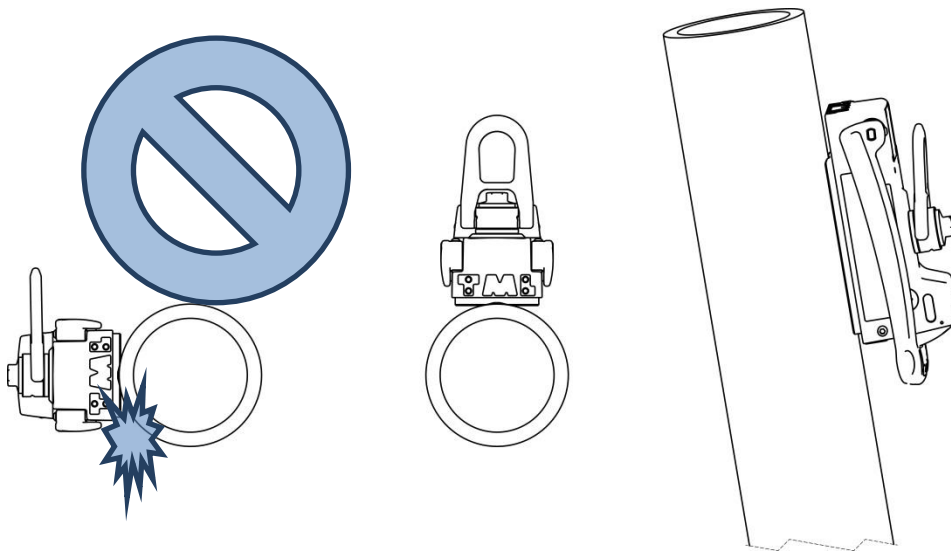

8. If the magnetic adhesion is sufficient and there is no deformation, you can continue the lift.
9. Be sure to move your load slowly and smoothly. Avoid swinging, jarring or quick and abrupt rotations. Especially round workpieces could disengage from the groove and immediately reduce the load-bearing capacity.
10. After the load has been set down completely and safely, you can deactivate the lifting magnet. To do this, press the safety tab using the heel of your hand and move the lever upwards into the OFF position.

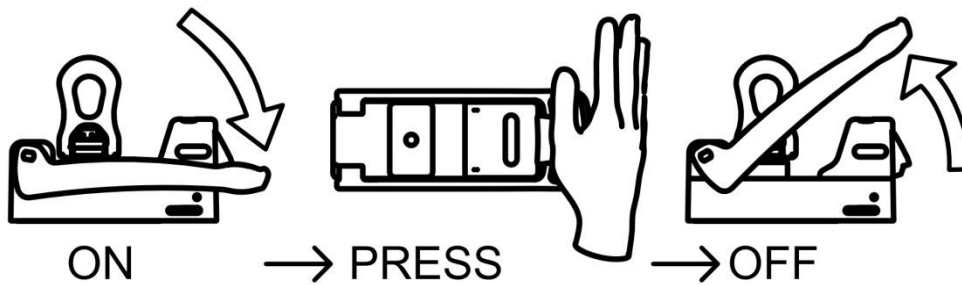

## Pivoting or Vertical Lifting of Loads

The special design of the MXL-1000.R lifting magnet allows the user to turn and pivot the load freely. The suspended load can be turned around at 360° and pivoted at 90° in most cases.

1. Be sure to use a flexible soft eye to avoid jamming the lifting magnet into the hook of the crane since this would lead to extremely unfavorable load conditions and the lifting capacity would no longer be assured. In addition, this will protect your magnet from damage and extend its lifetime.

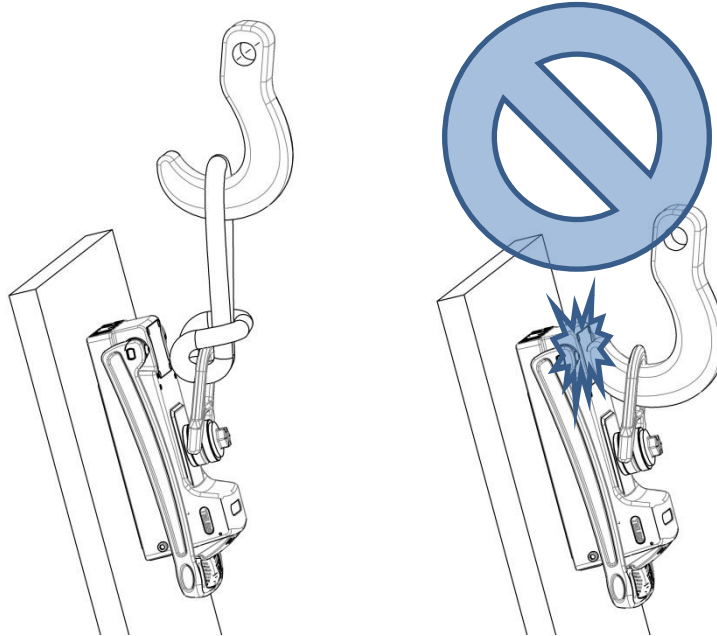
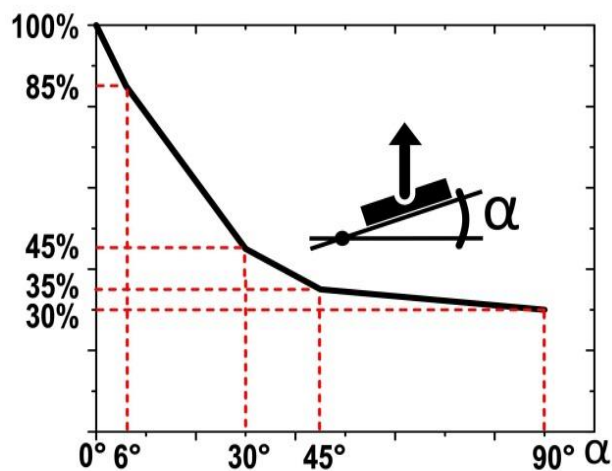

Figure 1

Figure 2

2. If the load is attached horizontally to the magnet, the entire breakaway force of the lifting magnet is acting on the load, so you can use 100 % of the lifting capacity as stated in table 2. However, if the load and the magnet surface tilt at an angle other than 0° to horizontal, the load-bearing capacity decreases due to the new alignment of the magnet to the gravity of Earth. As soon as the load is suspended vertically, i.e. at an angle of 90°, friction will be the only effect exerted by the magnet which is not more than 10-35 % of the maximum load-bearing capacity, depending on material being lifted.



Load-figures corresponding to the direction of the MXL-1000.R

You can calculate the maximum load-bearing capacity of your magnet, including the 3:1 safety factor, on the basis of the load-figure that corresponds to the direction.



**Example mm:**

You would like to lift a plate which is 6 mm thick and made of S235. The plate stands vertically, i.e. at an angle of 90°, in your shelf rack and your magnet is ideally positioned, as shown in figure 1.

- Material thickness: 6 mm → max. load-bearing capacity at 0° = 327 kg (see table 2)
- Material: S235 → holding force, subject to material = 100% (see table 1)
- Alignment of the load: 90° tilted; load hook facing upwards  
→ load-figure corresponding to direction = 30%

**Example INCH:**

You would like to lift a plate of mild Cold Rolled Steel (CRS) which is 1/4 inch thick. The plate stands vertically, i.e. at an angle of 90°, in your shelf rack and your magnet is ideally positioned, as shown in figure 1.

- Material thickness: 1/4 inch → max. load-bearing capacity at 0° = 717 lbs (see table 2)
- Material: mild steel → holding force, subject to material = 100% (see table 1)
- Alignment of the load: 90° tilted; load hook facing upwards  
→ load-figure corresponding to direction = 30%

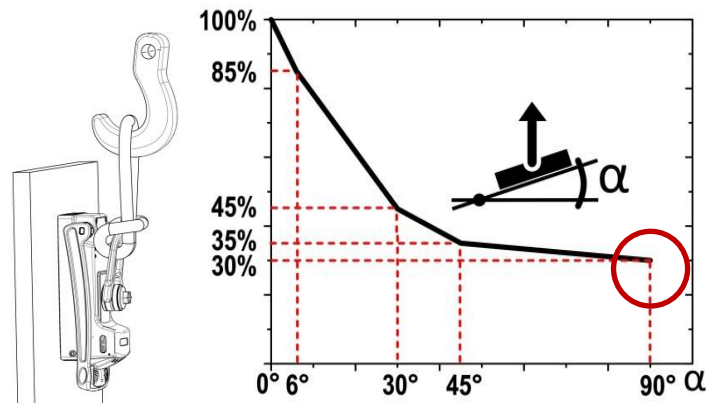

**Maximum load weight with 3:1 safety factor= 327 kg x 100% x 30% = 98.1 kg**

**Maximum load weight with 3:1 safety factor= 717 lbs x 100% x 30% = 215.1 lbs**

## Adjustable Shock Absorber

An oil filled shock absorber is incorporated on the backside of the magnet in order to absorb any recoil energy of the lever. The thinner the material to be lifted the higher the recoil energy to be absorbed. The set screw on the backside of the magnet makes it possible to adjust the shock absorber variably, so that the upward movement of the lever is controlled and operates smoothly. This adjustment should be made by using a flat-blade screwdriver.

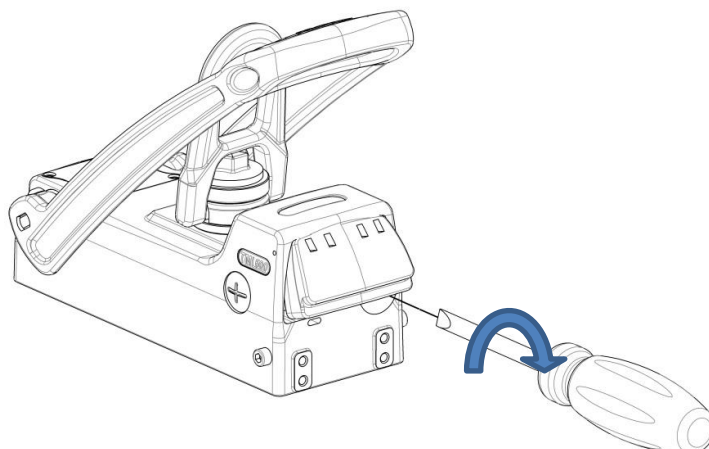

## Basic Information on the Load-bearing Capacity of the MXL-1000.R

The magnetic contact area is located on the underside of the magnet incorporating multiple magnetic poles which generate the magnetic holding force when activated. The maximum holding force that can be achieved depends upon different factors which are explained below:

### Material

Every material reacts in different ways to the penetration of magnetic field lines. The breakaway force of the magnetic contact area is determined by using common (low carbon) A36 steel. The given load-bearing capacity of the magnet should be De-Rated based on **Table 1**. It is up to the user to determine adequate magnetic holding force for alloys not shown in this table.

**Table 1**

Material	Magnetic force in %
Non-alloyed steel (0.1-0.3% C content, includes A36)	100
Non-alloyed steel (0.3-0.5% C content)	90-95
Cast steel	90
Grey castiron	45
Nickel	11
Stainless steel, aluminium, brass	0

### Material thickness

The magnetic flux (north to south field lines) of the permanent magnet requires a minimum material thickness to flow completely into and across the material below the magnetic contact area. Beyond this minimum material thickness, the maximum holding force continues to decrease (see **Detailed Performance Data**, Table 1).

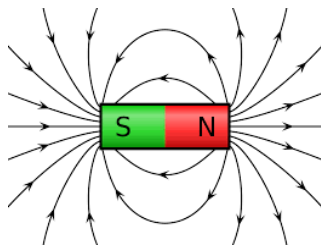

**Conventional (singular) switchable permanent magnet**

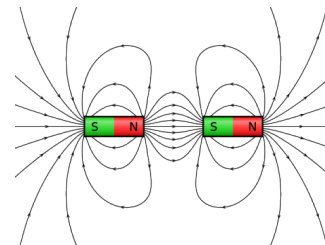

**Maglogix® (multi-field) switchable permanent magnet**

Conventional switchable permanent magnets have a deep penetrating singular (north to south) magnetic field. The way conventional switchable permanent magnets hold onto steel would be similar to stapling paper together using one large heavy staple in the center of the page, and not bending the legs together.

The compact multi-field magnetic array of the Maglogix® switchable permanent magnets would be similar to stapling paper together in a circular pattern with many small lightweight staples close together, and bending the legs together to achieve an even greater holding force. An infinite number of small magnetic field arrays are the principle behind the Maglogix® patented switchable lifting magnetics.

### Surface quality

The maximum holding force of a permanent magnet can be achieved in case of a closed magnetic circuit in which the magnetic field lines can connect up freely between the poles, thus creating a high magnetic flux. In contrast to iron, for example, air has very high resistance to magnetic flux. If an "air gap" (i.e. a space) is formed between the workpiece and the magnet contact area, the holding force will be reduced. In the same way, paint, rust, scale, surface coatings, grease or similar substances all constitute a space between the workpiece and magnetic contact area. Furthermore, an increase in surface roughness or unevenness has an adverse effect on the magnetic holding force. Reference values for your MXL-1000.R can also be found in **Table 2**.

### Load dimensions

When working with large workpieces such as girders or plates, the load can partly become deformed during the lift. A large steel plate would bend downwards at the outer edges and create a curved surface which no longer has full contact with the magnetic contact area. The resulting air gap reduces the maximum load-bearing capacity of the Lifting Magnet. Hollow objects or those smaller than the magnetic contact area of the magnet will also result in less holding power being available.

### Load alignment

During load movement care must be taken that the Lifting Magnet stays located at the workpiece center of gravity and that the Lifting Magnet's magnetic contact area respectively, stays balanced horizontally. In this scenario, the magnetic force of the Lifting Magnet's magnetic contact area and workpiece stay perpendicular to gravity, thus providing the maximum rated load-bearing capacity, resulting in a standard 3:1 safety factor.

**Danger:** If by accident the workpiece and Lifting Magnet shift or change from a horizontal to a vertical position, the Lifting Magnet is now transitioning into shear mode and the workpiece can slip away to the edge or even detach. In shear mode, the load-bearing capacity decreases dependent upon the coefficient of friction between the two materials.

### Maximum operating temperature

The high-power permanent magnets installed in the lifting magnet will maintain their load-bearing capacity up to a maximum operating temperature of 176°F (80°C). Exceeding this maximum operational temperature may cause irreversible damage.

## Maintenance and Inspection

The user is obliged to maintain and service the lifting magnet in compliance with the specifications in the operating manual and according to the country-specific standards and regulations (e.g. ASME B30.20B, DGUV-Information 209-013; AMVO).

The maintenance intervals are classified according to the recommended schedule.

### Before every use...

- visually inspect the lifting magnet for damage
- clean the surface of the workpiece and the underside of the magnet
- free the underside of the magnet of rust, chips or unevenness
- verify the lock function of the safety tab on the lever

### Weekly...

- inspect the lifting magnet and load hook for deformation, cracks or other defects
- make sure that the operating lever and safety tab are working properly
- inspect the load hook for damage or wear and have it replaced if necessary
- inspect the bottom of the magnet for scratches, pressure points or cracks and have the magnet repaired by the manufacturer if necessary

### Monthly...

- check the markings and labelling on the lifting magnet for legibility and damage and replace them if necessary

### Annually...

- have the load-bearing capacity of the lifting magnet checked by the supplier or an authorized workshop

An annual inspection is recommended for the safe use of this lifting magnet. We will be glad to perform this inspection for you in-house. Please send us an email to:

**[MX-Test@maglogix.com](mailto:MX-Test@maglogix.com)**

You will then promptly receive an offer and have the assurance that the lifting magnet will be inspected in a process-reliable manner where it was actually produced.



**Unauthorized repairs or modification to the lifting magnet are not permitted.  
If you have any questions contact the manufacturer.**

## Detailed Performance Data for Use on Flat Material

Values shown for the MXL-1000.R's load capacity are based on material S235 JR (comparable to AISI 1020 Cold Rolled Steel) with the maximum, vertical breakaway force at 0° deviation from the load axis and additionally under a 6° inclined load in accordance with EN13155, in each case with a 3:1 safety factor.

Table 2: Flat material

Thickness of material	Load capacity in lbs					
	Clean, flat, ground surface		Rusty, slightly scratched surface		Irregular, rusty or rough surface	
	Air gap < 0.004 inch		Air gap = 0.01 inch		Air gap = 0.02 inch	
inches	0°	6°	0°	6°	0°	6°
0.08	100	80	89	76	80	67
0.12	256	218	227	196	164	142
0.16	389	329	316	271	262	227
0.20	589	511	467	404	369	320
0.25	717	511	529	453	427	369
0.30	889	773	609	524	467	404
0.40	972	835	698	604	480	418
0.50	1000	844	711	613	484	422
>1	1000	862	724	627	493	427

Thickness of material	Load capacity in kg					
	Clean, flat, ground surface		Rusty, slightly scratched surface		Irregular, rusty or rough surface	
	Air gap < 0.1 mm		Air gap = 0.25 mm		Air gap = 0.5mm	
mm	0°	6°	0°	6°	0°	6°
2	45	40	41	35	36	32
3	118	100	104	91	77	65
4	177	154	145	127	123	104
5	272	236	218	186	173	150
6	327	286	245	213	200	173
8	413	359	281	245	218	186
10	445	390	327	281	236	204
15	454	400	331	286	227	195
>20	454	400	336	291	227	200

The maximum dimensions of the loads to be lifted depend to a large extent on the geometry and flexural stiffness of the work pieces. If the material bends, an air gap will form under the magnetic surface which will decrease the load-bearing capacity significantly.

During each lift, watch for any deformation of the work piece that might occur and check for any air gap developing at the edges of the magnetic surface contact area. You can use for instance a sheet of paper (80g/m<sup>2</sup>) to check this. Spreader bars with additional magnets may be required to safely lift large or flexible loads.

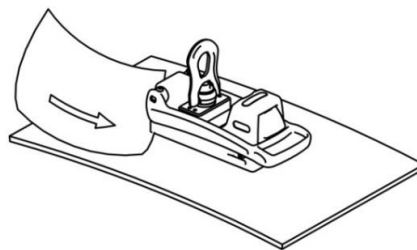

Immediately stop the lift if there is any excessive deformation of the work piece or an air gap.







Never exceed load-bearing capacity given in the table 2.

## Detailed Performance Data for Use on Round Pipes

Values shown for load capacity of the MXL-1000.R are based on material S235 JR for the maximum, vertical tractive force with 0° deviation from the load axis and a correct position of the pipe inside the groove of the magnetic contact area. The safety factor corresponds to at least 3:1 in all cases.

**Table 3: Round pipes**

inches	Load capacity in lbs					
	2"	3"	4"	8"	16"	
	>3/8	363	484	424	484	-
	5/16	351	484	424	484	-
	0.20	315	424	363	424	-
	0.16	230	315	271	315	-
	1/8	182	242	218	242	-

mm	Load capacity in kg					
	50	75	100	200	400	
	>10	165	220	193	220	-
	8	160	220	193	220	-
	5	143	193	165	193	-
	4	105	143	123	143	-
	3	83	110	99	110	-

Rust, paint or any other surface coating may cause an air gap that will reduce the load-bearing capacity according to the following table.

**Table 4: Air gap on round pipes**

<b>Air gap in mm</b>	0	0,2	0,4	0,6	1,0	1,5
<b>Air gap in inch</b>	0	0,0078	0,0157	0,0236	0,0393	0,0590
<b>Remaining load capacity in %</b>	<b>100</b>	<b>89</b>	<b>75</b>	<b>65</b>	<b>45</b>	<b>30</b>



Quick and abrupt rotations of the magnet can cause round object to disengage from the magnet's groove. This will reduce the load-bearing capacity immediately.



Never lift round pipes laterally or exceed the load-bearing capacity given in table 3 & 4.

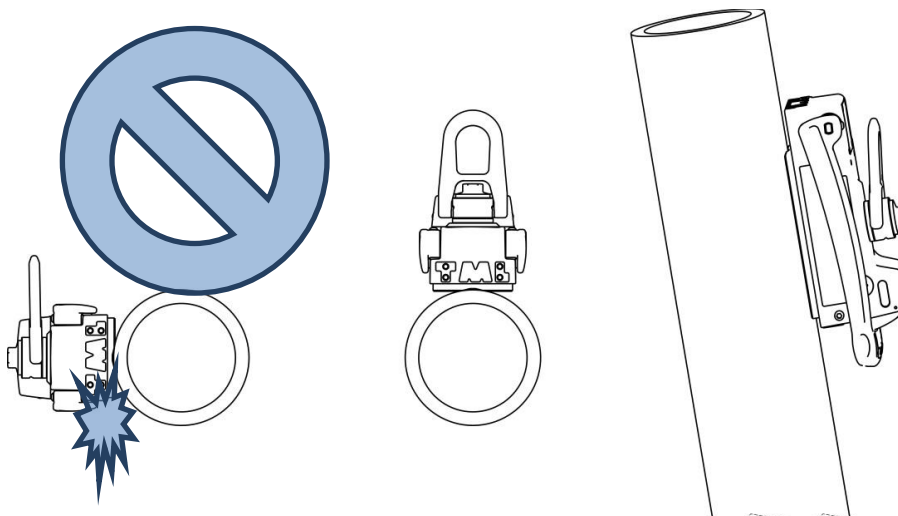

**EC Declaration of Conformity as defined by the Machinery Directive 2006/42/EC**

We,

Alfra GmbH  
2. Industriestr. 10  
68766 Hockenheim/Germany

hereby declare that the switchable permanent magnet-type lifting magnet

**MXL-1000.R**

from serial number 16H2669 onwards

complies with the following standards:

**EN ISO 12100:2010**

**EN 13155:2003+A2:2009**

This certificate is no longer valid if the product is modified without the manufacturer's consent. Furthermore, this certificate is no longer valid if the product is not used properly in accordance with the use cases documented in the user manual or if regular maintenance is not carried out in accordance with this manual or country-specific regulations.

Person authorized to compile the documents:

Alfra GmbH  
2. Industriestr. 10  
68766 Hockenheim/Germany

Hockenheim/Germany, 26.10.2017



Markus A. Döring  
(Managing Director)



