



Invented in the USA



**MAGLOGIX<sup>®</sup>**



Made in Germany / USA

**NO OTHER MAGNET EVEN COMES CLOSE!**

### 18343 Dimensions

### MagnaDrill™ MX-V Drill Stand

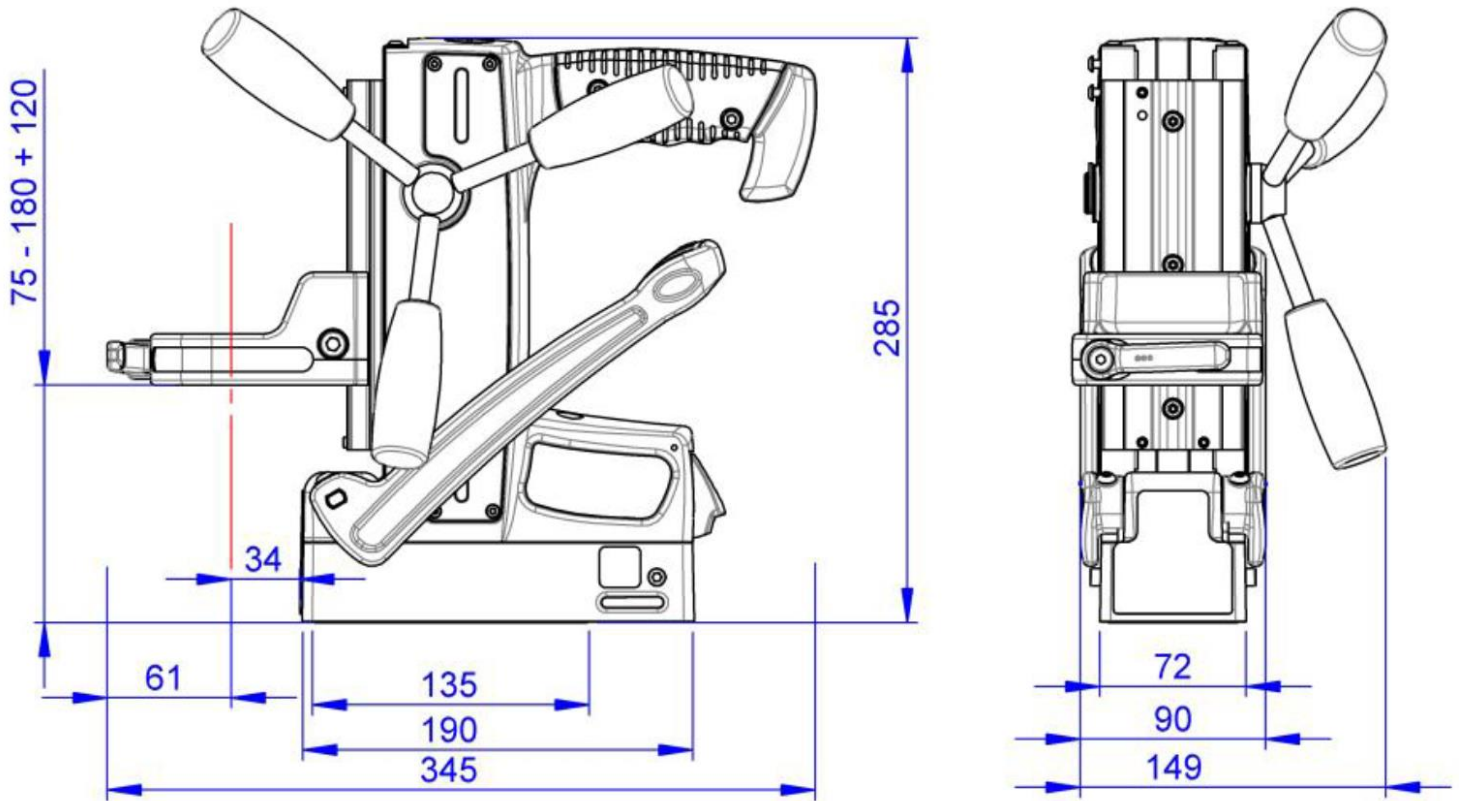

## Technical Data

|                            |   |  |
|----------------------------|---|--|
| Prod.-no. and designation: | <b>MagnaDrill® MX-V Drill Stand</b>       |  |
| Collar: Ø                  | 61.7 mm                                   |  |
|                            | incl. DeWalt adapter and 43mm             |  |
| Max. drilling Ø in steel   | 12 - 35 mm                                | 1/2" – 1 38/64"                                |
| - Core drill:              | up to Ø13 mm DIN 338                      | 1/2"   |
| - Twist drill:             |   |  |
| Stroke:                    | 105 mm + 80 mm height adjustment at slide | 4 18/32" + 3 18/32" height adjustment at slide |
| Size of magnetic base:     | 72 x 190 mm                               | 2 3/4" x 7 1/2"                                |
| Magnetic holding force:    | 7500 N                                    | 1686 lbs                                       |
| Tool force:                | 2800 N                                    | 630 lbs @ 3/8" steel                           |
| (on 10 mm steel)           |   |  |
| Tool force:                | 2300 N                                    | 520 lbs @ 2/8" steel                           |
| (on 6 mm steel)            |   |  |
| Min. material thickness:   | 3 mm                                      | 1/8"   |
| Weight:                    | 7 kg                                      | 15 lbs   |

- **Switchable Permanent Magnet Will Not Fall Off When The Power Goes Out**
- **Exceptional On Thin Steel And With Small Airgaps (<.020)**
- **Slight Magnetic Hold When The Magnet Is OFF For Ease Of Use And Positioning**
- **Lightweight And Comfortable For Less User Fatigue**
- **Accepts Most 1/2" Corded Drills As Well As Most Festool, Fein And Metabo Cordless Drills.**
- **Tool Holder Comes With Adapter For The Newest DeWalt 20 Volt Cordless Series (DCD995, 996, 997 And 998)**